



DESIGN, IMPLEMENTATION, AND DEPLOYMENT OF AN IOT BASED SMART ENERGY MANAGEMENT SYSTEM

M. Bhuvaneshwari*, S. Kannan**, S. Mohamed Shakith**, E. Yaswanth**
& P. Manimaran**

* Assistant Professor, Department of Electrical and Electronics Engineering, Dhanalakshmi Srinivasan Engineering College (Autonomous), Perambalur, Tamil Nadu, India

** UG Student, Department of Electrical and Electronics Engineering, Dhanalakshmi Srinivasan Engineering College (Autonomous), Perambalur, Tamil Nadu, India

Cite This Article: M. Bhuvaneshwari, S. Kannan, S. Mohamed Shakith, E. Yaswanth & P. Manimaran, "Design, Implementation, and Deployment of an IoT Based Smart Energy Management System", International Journal of Applied and Advanced Scientific Research, Volume 11, Issue 1, January - June, Page Number 80-82, 2026.

Copy Right: © DV Publication, 2026 (All Rights Reserved). This is an Open Access Article distributed under the Creative Commons Attribution License, which permits unrestricted use, distribution, and reproduction in any medium provided the original work is properly cited.

Type of Review: Peer Reviewed as per |C|O|P|E| Guidance.

Disclaimer: The scholarly papers reviewed and published by DV Publication, India, reflect the views and opinions of their respective authors and do not necessarily represent the views or opinions of DV Publication. The publisher disclaims any responsibility for any harm, loss, or damage resulting from the use of the published content by any party.

DOI: <https://doi.org/10.5281/zenodo.19808047>

Abstract:

This paper presents the design and implementation of an Internet of Things (IoT)-based Smart Energy Management System (SEMS) aimed at optimizing the utilization of both renewable and conventional energy sources. The proposed system is built around the ATmega328 microcontroller, which serves as the central processing unit for coordinating various components, including solar panels, batteries, sensors, and load management circuits. The primary objective is to enhance energy efficiency by prioritizing renewable sources such as solar power and intelligently switching to grid electricity only when necessary. The system also enables real-time monitoring and control through IoT integration, thereby improving energy utilization, reducing operational costs, and supporting sustainable development.

Key Words: IoT, Smart Energy Management System, ATmega328, Renewable Energy, Smart Grid

1. Introduction:

In recent years, the global energy landscape has undergone a significant transformation driven by the urgent need for sustainability, energy efficiency, and intelligent power management. The rapid increase in energy demand, depletion of fossil fuel resources, and rising environmental concerns due to carbon emissions have accelerated the transition toward renewable energy sources and smart consumption strategies.

The emergence of the Internet of Things (IoT) has revolutionized automation and data-driven decision-making across multiple domains, including energy systems. IoT enables real-time monitoring, control, and optimization of energy usage, making it a key enabler for smart grids and intelligent energy management systems. In this context, the development of an IoT-based Smart Energy Management System (SEMS) provides an effective solution for integrating renewable energy sources with conventional grid systems while ensuring efficient and reliable power distribution.

2. Objectives:

The primary objective of the proposed IoT-based Smart Energy Management System is to optimize energy utilization by integrating renewable and conventional energy sources through intelligent control mechanisms. The system employs an ATmega328 microcontroller to coordinate interactions between solar panels, battery storage, and the electrical grid.

The system prioritizes renewable energy to meet load demands, while grid power is utilized only when renewable generation is insufficient. Excess solar energy can be redirected to the grid, contributing to cost reduction and improved energy sustainability. This dynamic energy balancing approach ensures efficient operation under varying environmental and load conditions, making the system suitable for residential, commercial, and microgrid applications.

3. Existing System:

Existing energy management systems integrated with IoT technology provide platforms for real-time data acquisition, monitoring, and control. These systems utilize sensors to measure key electrical parameters such as voltage, current, power, and energy consumption. The collected data is transmitted to cloud servers, enabling remote access through web or mobile applications.

Disadvantages of Existing Systems:

- Limited measurement accuracy
- Inefficient data processing capabilities
- High maintenance requirements
- Dependence on weather conditions (for renewable sources)
- Lack of predictive fault detection mechanisms
- High implementation and operational costs

4. Proposed System:

The proposed IoT-based Smart Energy Management System is designed to intelligently coordinate renewable and conventional energy sources to achieve efficient, reliable, and sustainable power utilization. The system integrates solar panels, battery storage, sensors, load management units, and communication modules, all controlled by the ATmega328 microcontroller. The system operates based on a hierarchical energy utilization strategy:

- Primary Source: Solar energy
- Secondary Source: Battery storage
- Tertiary Source: Grid power

This structured approach ensures uninterrupted power supply while minimizing energy costs and maximizing the use of renewable energy.

Advantages:

- Improved measurement accuracy
- Real-time monitoring and control
- Enhanced system safety
- Reduced environmental impact
- Efficient asset and energy management

5. System Architecture:

The system architecture consists of interconnected modules, including solar panels, battery storage, sensors, microcontroller unit, load management circuits, and IoT communication modules. These components work collaboratively to ensure optimal energy distribution and monitoring.

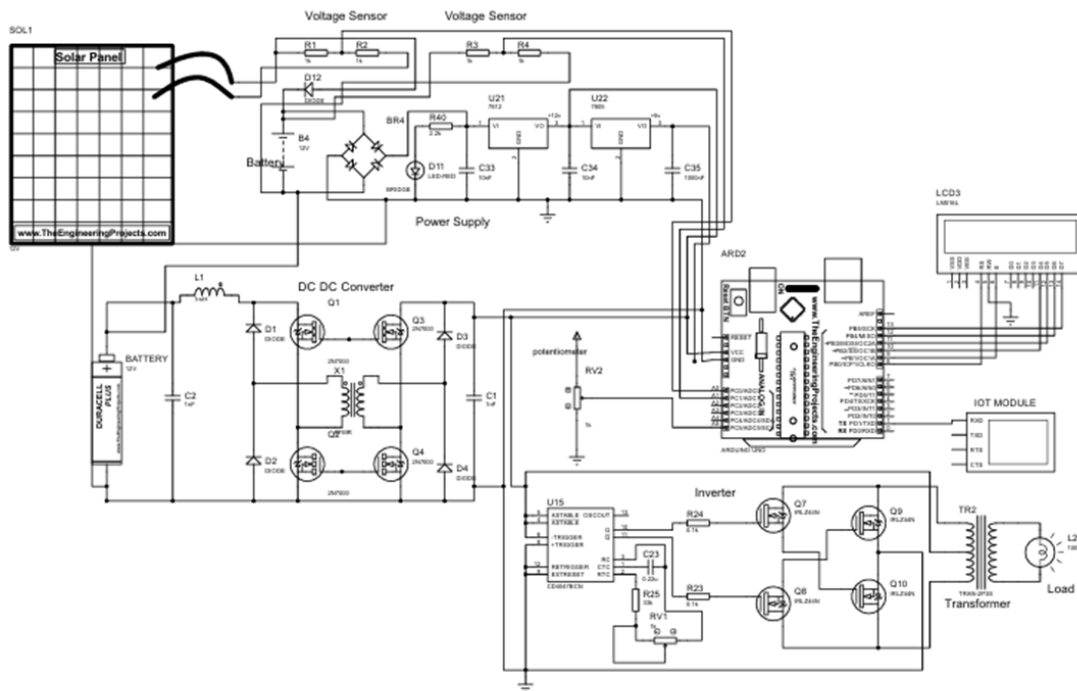

Figure 1: System Architecture

6. Block Diagram Explanation:

The system begins with a solar panel that converts sunlight into electrical energy. This energy is stored in a battery for later use. A regulated power supply unit ensures stable voltage and current levels for all system components.

Voltage Sensor 1 and Voltage Sensor 2 continuously monitor the output of the solar panel and battery, respectively. These measurements are processed by the ATmega328 microcontroller, which determines the appropriate mode of operation based on predefined thresholds.

- **Arduino Nano (ATmega328):** The Arduino Nano, based on the ATmega328 microcontroller, serves as the core controller of the system. It is programmed using the Arduino Integrated Development Environment (IDE), which provides a user-friendly interface for embedded system development. The microcontroller processes sensor data, executes control algorithms, and manages communication with the IoT module.
- **Voltage Sensor:** The voltage sensor measures the output voltage of the solar panel and battery using a resistive voltage divider network. This ensures compatibility with the microcontroller’s analog input range. The real-time data enables intelligent decision-making for switching between energy sources.
- **Potentiometer:** The potentiometer functions as a variable resistor used for system calibration and adjustment of reference parameters such as voltage thresholds and display contrast.
- **LCD Display:** A 16×2 Liquid Crystal Display (LCD) provides real-time visualization of system parameters, including voltage levels, energy consumption, and operational modes. It enhances user interaction by displaying status messages such as “SOLAR MODE,” “BATTERY MODE,” and “GRID MODE.”
- **IoT Module:** The IoT module (e.g., ESP8266 or ESP32) enables wireless communication between the system and cloud platforms. It allows users to remotely monitor and control energy usage via mobile or web applications.

Features of LCD:

- Operating voltage range: 3-20 V
- Response time: 50-200 ms
- Viewing angle: approximately 100°

- Requires external illumination in low-light conditions
- Typical lifespan: up to 50,000 hours

7. Conclusion:

The proposed IoT-based Smart Energy Management System offers an efficient and intelligent solution for modern energy challenges by integrating renewable and conventional power sources. The system ensures optimal energy utilization through real-time monitoring, automated control, and intelligent decision-making.

By leveraging IoT technology, users can remotely access system data, analyze energy consumption patterns, and make informed decisions to improve efficiency and reduce costs. The system not only enhances reliability and performance but also contributes to environmental sustainability by promoting the use of renewable energy sources.

References:

1. M. U. Saleem, M. R. Usman, M. A. Usman and C. Politis, "Design, Deployment and Performance Evaluation of an IoT Based Smart Energy Management System for Demand Side Management in Smart Grid," in IEEE Access, vol. 10, pp. 15261-15278, 2022, doi: 10.1109/ACCESS.2022.3147484.
2. M. U. Saleem, M. R. Usman and M. Shakir, "Design, Implementation, and Deployment of an IoT Based Smart Energy Management System," in IEEE Access, vol. 9, pp. 59649-59664, 2021, doi: 10.1109/ACCESS.2021.3070960.
3. C. Balasubramanian and R. L. Raja Singh, "IoT Based Energy Management System in Smart Grid," 2023 Innovations in Power and Advanced Computing Technologies (i-PACT), Kuala Lumpur, Malaysia, 2023, pp. 1-6, doi: 10.1109/i-PACT58649.2023.10434561.
4. L. Raju, S. S and S. S, "IOT and App based Novel Robust Smart Energy Management and Demand side Management of microgrids," 2024 10th International Conference on Electrical Energy Systems (ICEES), Chennai, India, 2024, pp. 1-6, doi: 10.1109/ICEES61253.2024.10776845.
5. A. T. Al Ghazo and M. Salah, "IoT and AI-Driven Smart Power Management System for Optimizing Resource Usage in Smart Buildings: The Faculty of Engineering at the Hashemite University Case Study," 2025 IEEE 22nd International Multi-Conference on Systems, Signals & Devices (SSD), Monastir, Tunisia, 2025, pp. 637-645, doi: 10.1109/SSD6418.2.2025.10989878.
6. Y. Zhu and M. Yue, "Design of an IoT-Based Smart City Energy Management System," 2025 4th International Conference on Green Energy and Power Systems (ICGEPS), Hangzhou, China, 2025, pp. 489-492, doi: 10.1109/ICGEP565133.2025.11034388.
7. P. M R and B. Bhowmik, "Development of IoT-Based Smart Home Application with Energy Management," 2023 International Conference on Sustainable Communication Networks and Application (ICSCNA), Theni, India, 2023, pp. 367-373, doi: 10.1109/ICSCNA58489.2023.10370276.
8. V. Dankan Gowda, S. G. Surya, N. M. G. Kumar, K. Prasad, V. S. Prasad and M. Kaur, "Optimizing Renewable Energy Integration in Smart Grids through IoT-Driven Management Systems," 2024 2nd International Conference on Advancement in Computation & Computer Technologies (InCACCT), Gharuan, India, 2024, pp. 783-788, doi: 10.1109/InCACCT61598.2024.10551160.
9. K. Katuri, J. Somalal, R. S. Kumar, B. H. Kumar, V. S. Chandrika and Y. K. Kishore, "Monitoring and controlling of Solar Driven Real Time Smart Energy Management System Integrated with IoT Devices," 2023 Second International Conference on Trends in Electrical, Electronics, and Computer Engineering (TEECCON), Bangalore, India, 2023, pp. 347-352, doi: 10.1109/TEECCON59234.2023.10335856.
10. S. Kumar, K. Suneetha and A. Gill, "Utilization of IoT and Smart Meters for Energy Management," 2023 International Conference on Power Energy, Environment & Intelligent Control (PEEIC), Greater Noida, India, 2023, pp. 1254-1258, doi: 10.1109/PEEIC59336.2023.10450474.